

Square steel grille with beveled edges and white finish includes a separate subplate that direct-mounts an 8" speaker and enclosure. The direct-mount method allows a high quality 8" speaker with substantial motor structure weight to be supported by the enclosure instead of the grille.

### FEATURES:

- **Construction:** Grille is a 20-gauge steel beveled frame with a radius corner cutout, welded 22-gauge perforated screen center, and white powder epoxy finish. The separate subplate is 21-gauge steel with black powder epoxy finish.
- **Overall Dimensions:** 12.375" square
- **Mounting Projection:** 0.375"
- **Mounting Bolt Circle (subplate):** 12.8" and 11.25" diameter
- **Speaker Bolt Circle:** 7.68" diameter
- **Country of Origin:** Made in USA with certified US steel
- **Hardware (included):**
  - (4) 8-32 x 3/4" black oxide screws with nuts to mount an 8" EIA speaker to the subplate.
  - (4) 8-32 x 2" black oxide screws to mount the speaker/subplate assembly to an enclosure, which allows a high quality 8" speaker with substantial motor structure weight to be supported by the enclosure instead of the grille.
  - (4) 8-32 x 3/4" white screws to mount the non-loadbearing grille to the enclosure.
- **A&E Specifications:** The grille for 8" speakers shall be Lowell model JG-8X. It shall be a 20-gauge steel beveled frame with a radius corner cutout, welded 22-gauge perforated screen center and white powder epoxy finish. It shall include a separate subplate, which shall be 21-gauge steel with black powder epoxy finish. Overall grille measurements shall be 12.375" square with a mounting projection of 0.375". The subplate shall direct-mount an 8" EIA speaker and enclosure. The non-loadbearing grille shall include white screws to mount to the backbox. The grille and subplate shall be made in the U.S.A.

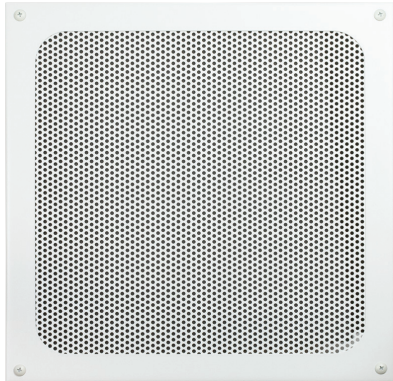

Front

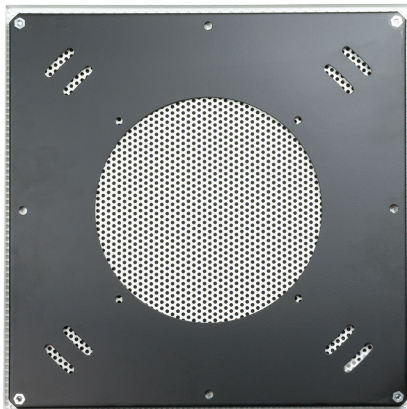

Rear (with subplate)



### COMPATIBLE COMPONENTS (order separately):

*Note: Grilles are designed to work with speakers, enclosures, and mounting accessories listed on this specification sheet. Using the grille to install speakers without a metal enclosure may not meet the requirements of all local and national electrical and building codes. The installer should request approval of the installation method from the Authority Having Jurisdiction (AHJ) before installing the speaker system.*

Application	Speaker	Enclosure	Mounting Aids
<b>SURFACE-mount</b> with enclosure	8" EIA	CB84A, CB86A, CB88	-----
<b>RECESSED in Tile Ceiling</b> with enclosure	8" EIA	P68X, P68XA (4"D), P68X-6, P68XA-6 (6"D), P875X-6	SS24, SS30, or SS48 tile support rails or contractor's custom hardware
<b>RECESSED in Tile Ceiling</b> without enclosure	8" EIA	-----	LBS8, LBS8-R1 (t-bridge)
<b>RECESSED Before Drywall Installed</b> with enclosure	8" EIA	P68X, P68XA (4"D), P68X-6, P68XA-6 (6"D), P875X-6	SS24, SS30, or SS48 mounting rails (to span ceiling structural members) or contractor's custom hardware
<b>RECESSED Retrofit in Existing Drywall</b>	8" EIA	P68XA (4"D) P68XA-6 (6"D)	SS9 retrofit mounting rails or contractor's custom hardware

*Note: Robust coaxial speakers, such as Lowell 8A50 or 8P100, require a large volume enclosure (greater than 4"D).*

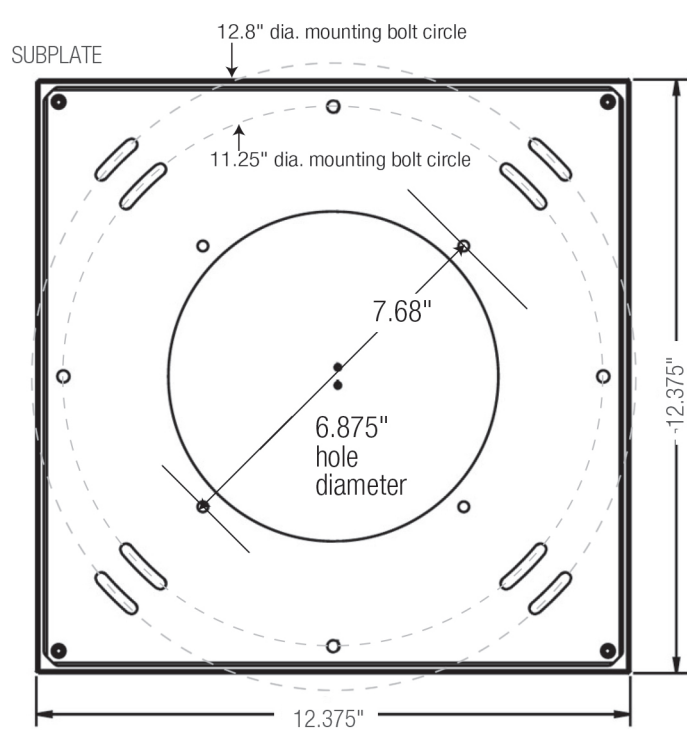

**PERFORMANCE NOTE:**

The black steel subplate includes slots to allow it to be mounted to enclosures with two (2) different mounting centers, and the curved slots allow the orientation of the subplate to be adjusted, even if the installation of the enclosure was not perfectly straight. It is important to note that those open slots can result in loss of low frequency response. For critical applications where superior low frequency response is required, Lowell recommends that the installer seal the curved slots with a very durable tape or sealant, after the subplate has been mounted.

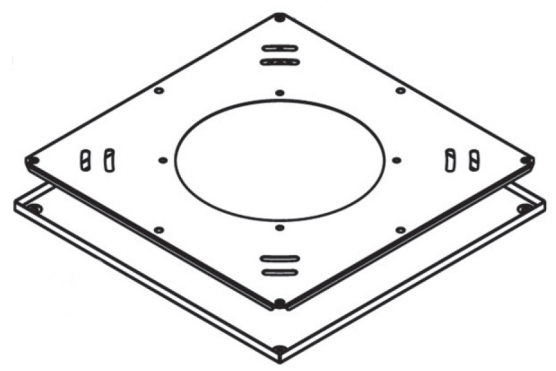
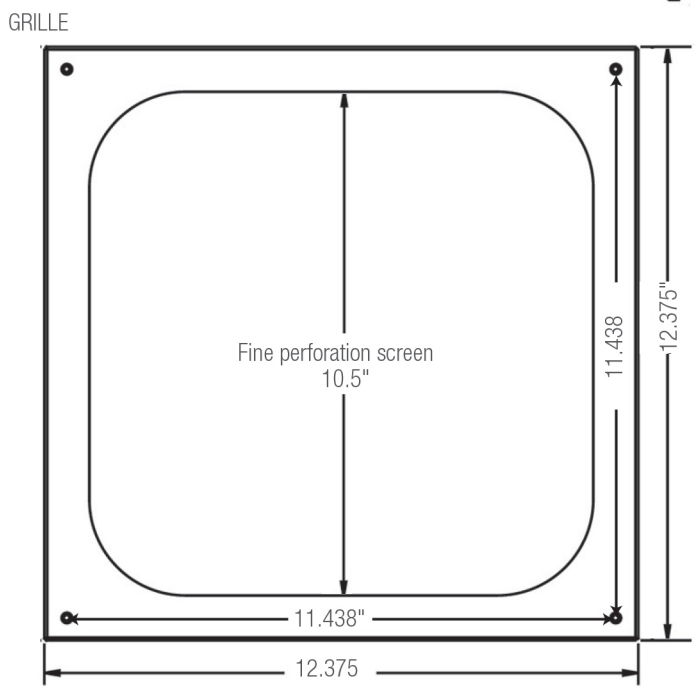
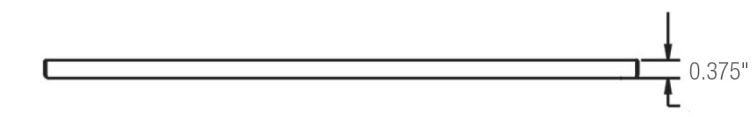

**WARNING!** Speaker installation should only be performed by experienced qualified professionals with knowledge of load-rated hardware and safe installation, mounting, and rigging techniques. Improperly installed equipment can result in property damage, personal injury, death, and/or liability to the installing contractor. The speaker system must be mounted in accordance with all local, state, and federal codes and regulations and the installation must conform to industry standard practices. It is the responsibility of the installer to furnish all installation hardware, rigging hardware, and safety or restraint cables to be used. Before installation, it is the responsibility of the installer to consult a licensed mechanical or structural engineer to evaluate and certify the structural integrity and safety of any mounting method and the suitability of that method to be used to mount the loudspeaker to the building structure in this particular installation. Lowell Manufacturing is not responsible for the use, misuse, misapplication, or unsafe installation of this loudspeaker product.